

REINFORCING RODS:
 5/8"φ ON TOP, 3/4"φ ON BOTTOM,
 LOCATED 12" ON CENTER

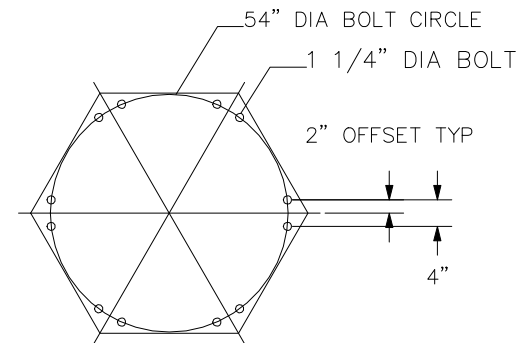

12 BOLT
 BASE BOLT PATTERN
 1 1/4" BASE PLATE THICKNESS AT ANCHOR BOLT
 VIEW A-A
 NOT TO SCALE

CREATED BY: HOOSIER CRANE SERVICE

CONFIDENTIAL

GORBEL

600 FISHERS RUN
 P.O. BOX 593
 FISHERS, NY 14453-0593

MODEL NO.: FS300-24-W18

CAPACITY: 5.000 TON
 SPAN: 12'-0"
 H.U.B.: 10'-0"

QUANTITY: 1
 SHIPPING WT.: 3728 LBS

DRAWN: lauyod DATE: DEC 29, 2014

C.O.#: test P/N: test.1A

- NOTES:
- 1) JIB CRANE FOUNDATION REQUIREMENTS ARE BASED ON A SOIL PRESSURE OF 2500 LBS PER SQUARE FOOT. CONCRETE RECOMMENDED FOR JIB CRANE FOUNDATION IS 3000 LBS PER SQUARE INCH OF COMPRESSIVE FORCE.
 - 2) DO NOT SCALE FROM THIS DRAWING.
 - 3) OVERALL HEIGHT = 11'-6"